

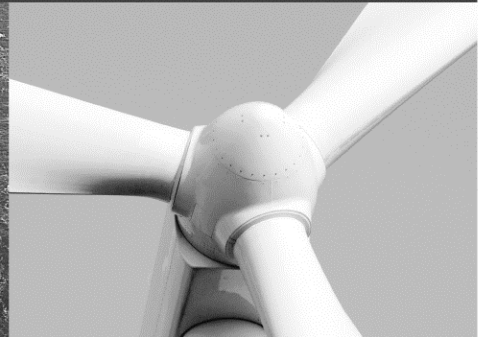

-power in control

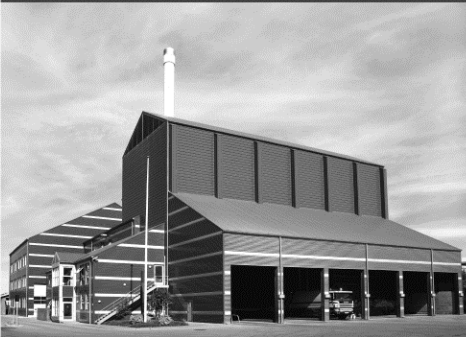

## DATA SHEET



### **CIO 116 | 16 digital inputs** **CAN bus-based I/O module**

- 16 digital inputs
- Positive or negative common for 2 × 8 inputs
- CAN bus interface
- LEDs to indicate status and input state
- 12/24 V DC supply



DEIF A/S · Frisenborgvej 33 · DK-7800 Skive  
Tel.: +45 9614 9614 · Fax: +45 9614 9615  
info@deif.com · www.deif.com

Document no.: 4921240524A

**Application**

The CIO series is a range of external I/O modules for some DEIF controllers, in case the demand for inputs and outputs exceeds the capacity of the controller.

**Host controllers**

The CIO modules need a host controller to send and receive their information.

The controllers that are listed below support CIO modules:

Type	SW version	CIO 116 quantity	CIO 208 quantity	CIO 308 quantity
AGC 200	From v4.57	3	3	3
AGC-4	From v4.58	3	3	3

**Common functions****Status output**

The status output is active when the CIO module works correctly and communication to the host controller is established. The microprocessor is supervised by a watchdog.

**Note:**

The status output can be re-configured as a configurable output. In this case, the states above may not be true. Re-configuration of the status output is not possible on marine-approved DEIF host controllers (PPM and PPU).

**Status LED**

The status LED (LED1) indicates the operation status of the module and the status output.

**CAN LED**

The CAN LED (LED2) indicates the status of the CAN bus communication to the host controller.

**CAN bus end resistor**

The CIO module has a built-in 120 ohm end-termination for the CAN bus line, which can be activated via the switch (S1).

**Input LEDs**

All 16 inputs have a green LED next to the input terminal to indicate the state of the input.

**ID selector**

The ID selector is used to give CIO modules of the same type different IDs.

All three types of CIO modules can use IDs from 1 to 15, and different module types may use the same ID.

**USB connection**

The USB port can only be used to update the firmware of the module. Configuration is not possible via this port.

**Note:**

To update the firmware, the CIO module ID switch must be set to ID 0.

**CAN bus**

The CAN bus interface is intended for DEIF host controllers only. It is possible to have additional CAN bus communication devices (J1939) on the same CAN bus line, but they cannot act as host for the CIO module. It is described in the manual of the host controller if it supports this feature.

CIO 116 hardware

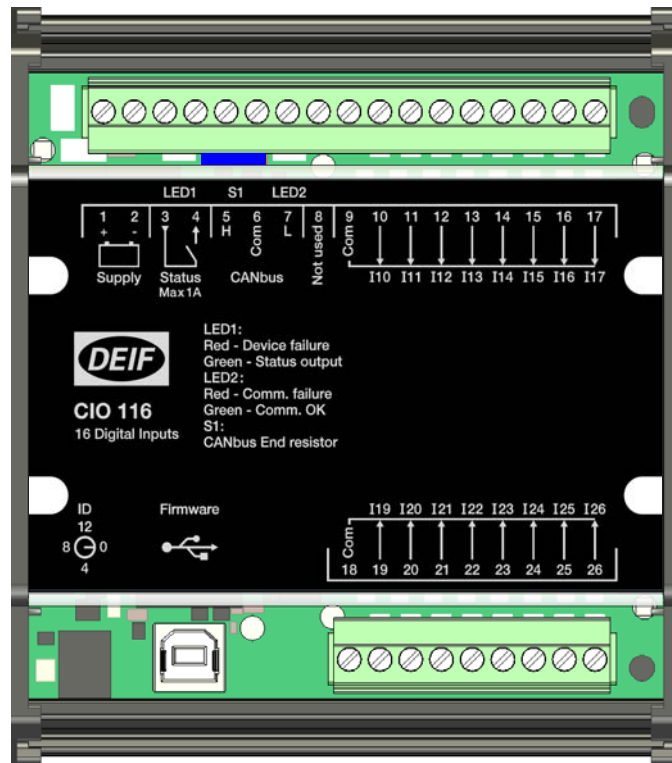

Terminal	Name	Description	Comment
1	+	+12/24 V DC	Power supply
2	-	0 V DC	
3	Status	Common	Status output (configurable)
4		Normally open	
5	H	CAN H	CAN bus interface
6	Com	CAN Com	
7	L	CAN L	
8	Not used		
9	Com	Common	Common for terminals 10-17
10	I10	Input 10	Digital input group 1
11	I11	Input 11	
12	I12	Input 12	
13	I13	Input 13	
14	I14	Input 14	
15	I15	Input 15	
16	I16	Input 16	
17	I17	Input 17	
18	Com	Common	Common for terminals 19-26
19	I19	Input 19	Digital input group 2
20	I20	Input 20	
21	I21	Input 21	
22	I22	Input 22	
23	I23	Input 23	
24	I24	Input 24	
25	I25	Input 25	
26	I26	Input 26	

**Available variants**

Type	Variant no.	Description	Item no.	Note
CIO 116	01	CIO 116 – 16 digital inputs	2912890240	16 × digital inputs

## Technical specifications

<b>Operating temp.:</b>	-40 to +70 °C (-40 to 158 °F) to IEC 60068-2-1/2  <b>UL/cUL Listed:</b> Max. surrounding air temperature 70 °C (158 °F)
<b>Storage temp.:</b>	-40 to +70 °C (-40 to +158 °F)
<b>Climate:</b>	97 % RH to IEC 60068-2-30
<b>Operating altitude:</b>	Max. 4000 meters above sea-level
<b>Aux. supply:</b>	Nominal 12/24 V DC (operational 6.0 to 36 V DC)  Able to survive 0 V DC for maximum 50 ms when coming from at least 12 V DC (cranking dropout)  The aux. supply input is to be protected by a 2 A slow-blow fuse If protection against load dump is required, use a 12 A slow-blow fuse  <b>UL/cUL Listed:</b> 7.5 to 32.5 V DC
<b>Consumption:</b>	Max. 0.5 W
<b>Load dump:</b>	ISO 16750-2 Test A (24 V DC system) SAE J1113-11 Pulse 5 A Power supply ports: Test 1 – 123 V at 1 Ω for 100 ms Test 2 – 174 V at 8 Ω for 350 ms
<b>Status output:</b>	Solid state output Maximum 30 V AC or DC Temperature from -40 to +40 °C max. 1 A resistive load Temperature from +40 to +70 °C max. 0.8 A resistive load
<b>Digital inputs:</b>	Optocoupler, bi-directional Input ON detection from +/-8 V to +/-36 V DC Input OFF detection <2 V DC Input impedance 4.7 kΩ
<b>Galvanic separation:</b>	Between digital inputs and other I/Os: 600 V 50 Hz for 1 minute Between digital input group 1 and 2: 600 V 50 Hz for 1 minute Between CAN bus interface and other I/Os: 600 V 50 Hz for 1 minute Between status relay output and other I/Os: 600 V 50 Hz for 1 minute
<b>Mounting:</b>	DIN rail mounting inside a cabinet or other enclosure Compatible DIN rails: - TS35/top hat 35 mm (this rail type is used in all product tests) According to EN 50022 - G-type rail According to EN 50035, BS 5825, DIN 46277-1  <b>UL/cUL Listed:</b> To be installed in accordance with the NEC (US) or the CEC (Canada)
<b>Connections:</b>	Minimum 0.2 mm <sup>2</sup> (24 AWG) multi-stranded Maximum 2.5 mm <sup>2</sup> (12 AWG) multi-stranded Firmware port: USB-B  <b>UL/cUL Listed:</b> Use min. 90 °C copper conductors only
<b>Terminals tightening torque:</b>	Minimum 0.5 Nm (4.4 lb-in) Maximum 0.6 Nm (5.3 lb-in)  <b>UL/cUL Listed:</b> 0.5 Nm (4.4 lb-in)
<b>Approvals:</b>	CE UL/cUL Listed to UL508 and CSA C.22.2 No. 142-M1987 UL/cUL Recognized to UL6200 and CSA C.22.2 No. 14-13 (pending)

<b>Weight:</b>	260 g (0.57 lbs)
<b>Safety:</b>	IEC/EN 60255-27, CAT III, 50 V, pollution degree 2
<b>Protection:</b>	IP20 - IEC/EN 60529 NEMA type 1  <b>UL/cUL Listed:</b> Type complete device, Open Type 1
<b>EMC/CE:</b>	EN 61000-6-1/2/3/4 IEC/EN 60255-26 IEC 60533 power distr. zone IACS UR E10 power distr. zone
<b>Vibration:</b>	Test performed with CIO module mounted on top hat 35 mm DIN rail 3 to 13.2 Hz: 2 mm <sub>pp</sub> 13.2 to 100 Hz: 0.7 g To IEC 60068-2-6 To IACS UR E10  10 to 58.1 Hz: 0.15 mm <sub>pp</sub> 58.1 to 150 Hz: 1 g To IEC 60255-21-1 Response (class 2)  10 to 150 Hz: 2 g To IEC 60255-21-1 Endurance (class 2)  3 to 8.15 Hz: 15 mm <sub>pp</sub> 8.15 to 35 Hz: 2 g To IEC 60255-21-3 Seismic (class 2)
<b>Shock:</b>	Test performed with CIO module mounted on top hat 35 mm DIN rail 10 g, 11 msec, half sine To IEC 60255-21-2 Response test (class 2)  30 g, 11 msec, half sine To IEC 60255-21-2 Withstand test (class 2)  50 g, 11 msec, half sine To IEC 60068-2-27
<b>Bump:</b>	Test performed with CIO module mounted on top hat 35 mm DIN rail 20 g, 16 msec, half sine To IEC 60255-21-2 (class 2)
<b>Material:</b>	All plastic materials are self-extinguishing according to UL94 (V1)

**Unit dimensions in mm (inches)**

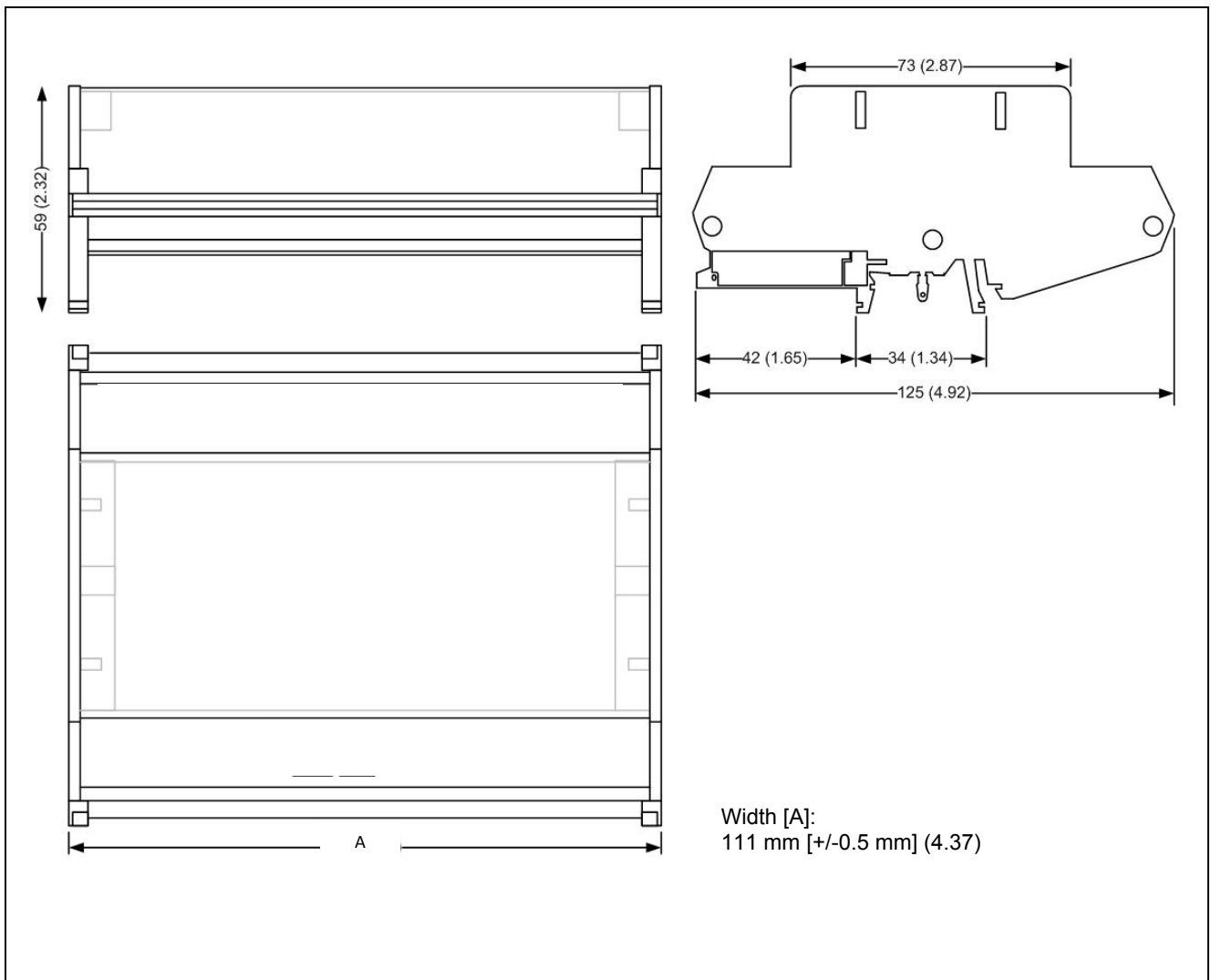

**Order specifications**

Variants:

Mandatory information		
Item no.	Type	Variant no.

Example:

Mandatory information		
Item no.	Type	Variant no.
2912890240-01	CIO 116	01

Due to our continuous development we reserve the right to supply equipment which may vary from the described.



**DEIF A/S**, Frisenborgvej 33  
DK-7800 Skive, Denmark

Tel.: +45 9614 9614, Fax: +45 9614 9615  
E-mail: [deif@deif.com](mailto:deif@deif.com), URL: [www.deif.com](http://www.deif.com)

